

A Comparison Analysis of Unipolar and Bipolar Switching modulated Cascade H-Bridge Multi Level Inverters

Manikanth Addala*, KRK Pandu**, V.Satyanarayana***

* (PG Scholar, Department of EEE, Ramachandra College of Engineering, Vatluru(V), Eluru, West Godavari (Dist), Andhra Pradesh)

** (Assistant Professor, Department of EEE, Ramachandra College of Engineering, Vatluru(V), Eluru, West Godavari (Dist), Andhra Pradesh)

*** (Associate Professor, Department of EEE, Ramachandra College of Engineering, Vatluru(V), Eluru, West Godavari (Dist), Andhra Pradesh)

ABSTRACT

This paper discusses controlling of cascaded H-bridge multi inverter with sinusoidal modulation based PWM methods. Multi-level inverters are used to reduce the THD in the output wave form without reduction in power output of inverter. Increase in voltage level in the output voltage of an inverter increases numbers of components to be used in inverter configuration. This in turn increases the switching loss. But results in good harmonic distortion and provide better quality fundamental wave. Carrier based PWM schemes are used for control of switching operation of multi-level inverters. Many kinds of PWM schemes are available to control inverter switches. In this paper unipolar carrier based PWM, bipolar carrier based PWM schemes are considered for generation of carrier signals. The carrier signals thus generated are compared with sinusoidal and third harmonic based sinusoidal modulating signals for production of switching Pulses. Switching schemes are designed for a 3 Phase 3, 5, 7, 9 and 11 Level inverters. The proposed switching schemes are applied to Cascaded H-Bridge Multi Level inverters. The circuit is simulated with MATLAB Simulink environment for verification of total harmonic distortion.

Keywords - Bipolar carrier signals, Cascaded H-bridge multi-level inverter, MATLAB Simulink, sinusoidal pulse width modulation, third harmonic based sinusoidal pulse width modulation, unipolar carrier signals.

I. Introduction

Recently multilevel inverters have become more attractive to researchers and industrial companies due to fast developing of high power devices and related control techniques (Khajehoddin et al., 2007). The recent advancement in power electronics has initiated to improve the level of inverter to cater to the need of medium voltage high power applications without transformer (KjaerefoJ.,2005).

The three common topologies for multilevel inverters are as follows: Diode clamped (neutral clamped), capacitor clamped (flying capacitors), cascaded H-bridge inverter but the one considered in this study is the cascaded H-bridge multilevel inverter. These converter topologies can generate high-quality voltage waveforms with power semiconductor switches operating at a frequency near the fundamental. It significantly reduces the harmonics problem with reduced voltage stress across the switch (Kjaerefa/, 2005). The cascaded H-bridge multilevel inverter topology has many advantages not only in terms of its simple structure but also allows the use of a single dc source as the first dc source with the remaining (n-1) dc sources being capacitors (Seyezhai and Mathur, 2010). The voltage regulation of the capacitor is the key issue

and this is achieved by the switching state redundancy of the proposed modulation strategy. This scheme also provides the ability to produce higher voltages at higher speeds with low switching losses and high conversion efficiency. The cascaded multilevel control method is very easy when compared to other multilevel inverter because it doesn't require any clamping diode and flying capacitor (Mafhurm and Seyezhai, 2008).

The diode-clamped inverter (neutral-point clamped), capacitor-clamped (flying capacitor) requiring only one dc source and the cascaded bridge inverter requiring separate dc sources. The latter characteristic which is a drawback when a single dc source is available becomes a very attractive feature in the case of PV Systems because solar cells can be assembled in a number of separate generators. In this way, they satisfy the requirements of the CHB-MLI, obtaining additional advantages such as a possible elimination of the dc/dc booster (needed in order to adapt voltage levels), a significant reduction of the power drops caused by sun darkening (usually, it influences only a fraction of the overall PV field) and therefore, a potential increase of efficiency and reliability (Aghdam et al, 2008).

Performance of the multilevel inverter (such as THD) is mainly decided by the modulation strategies.

For the cascaded multilevel inverter there are several well known pulse width modulation strategies such as space vector pwm, sinusoidal pwm, selective harmonics elimination and multicarrier pwm (Tolbert et al, 1999). Compared to the conventional method, the proposed method is subjected to a new modulation scheme adopting the multicarrier pulse width modulation concept which uses multiple modulating signals with a single carrier reduces the total harmonic distortion (Rodriguez et al., 2002).

This research study deals with harmonic analysis in 5, 7, 9 and 11 levels by considering up to 23rd harmonics of single phase cascaded H-bridge multilevel inverter employing multicarrier pulse width modulation technique for grid connected photovoltaic system. The effect of cascaded h-bridge multilevel inverter topology and change in PV input parameters irradiation and temperature on the performance parameters has been analyzed.

II. Cascaded H-Bridge Multi-level Inverter

Multi-level inverters have emerged recently as very important role in the area of high power and medium voltage applications. The multi-level inverters are, (i) diode clamped multi-level inverters (ii) flying capacitor multi-level inverter (iii) cascaded H-bridge multi-level inverter, the cascaded H-bridge multi-level inverter have some disadvantages compared to other topologies, because it have the full H-bridges that improving the level of the voltages. Same numbers of components are sufficient for each level. In sinusoidal pulse width modulation, sine wave is compared with the carrier wave, the pulses are produced. Then that produces pulses given to the multi-level inverters, in SVPWM modulating waves are compared with the carrier wave that produced pulses also given to the multi-level inverters. Carrier based schemes are used for multi-level inverters. Number of carriers are depends on the levels of the multi-level inverters. For five level inverts four carriers are used.

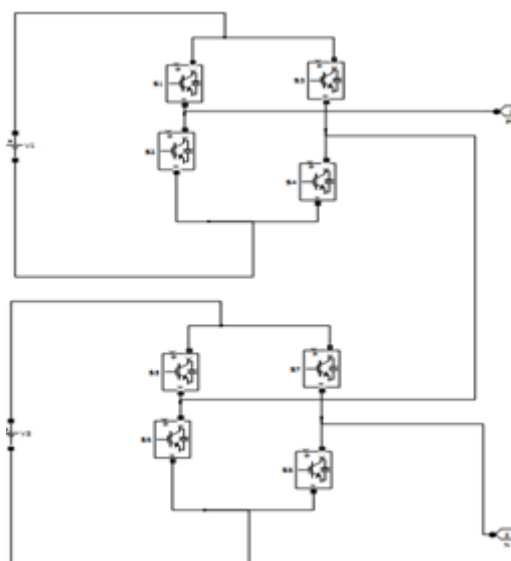

Fig 1: Cascaded H Bridge based Multilevel Inverter

In cascaded H-bridge multi-level inverter uses cascaded full bridge inverters with separate DC sources, number of devices used in the circuit are less. Using of H- bridges multilevel inverter increases the voltage level of the inverter. The fig 1 shows cascaded H-bridge based multi-level inverter. This requires less no of components, same amount of components are sufficient in every voltage level. For different voltage level the operation of switching sequence will be following in the table1, when the battery has 2Vdc voltage. For zero voltage the S1, S3, S5, S7 switches get ON. For Vdc Voltage S2 S6 S8 S2 switches will be ON. For 2Vdc voltage S1, S6, S5, S2 switches will be ON, For -2Vdc voltage S3,S8,S7,S4 switches will be ON, For -Vdc voltage S3,S7,S5,S4 switches will be ON.

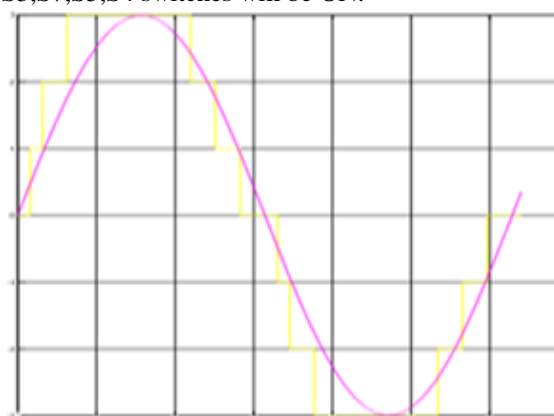

Fig 2: Output of a Seven Level Inverter.

III. Sinusoidal Pulse Width Modulation

In the sinusoidal pulse width modulation, the reference wave is the sine wave. That is compared with the carrier triangular Wave, the pulses are produced. That is given to the inverter. The sine

wave is greater than the carrier wave the top switches are ON. Otherwise the bottom switches are ON.

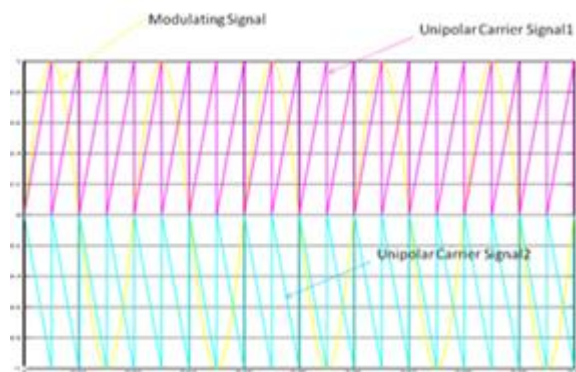

Fig 3: Unipolar switching sequence generation.

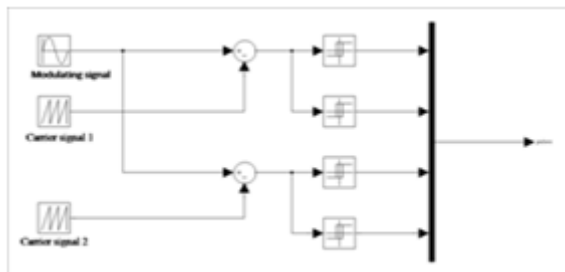

Fig 4: Unipolar Switching signals.

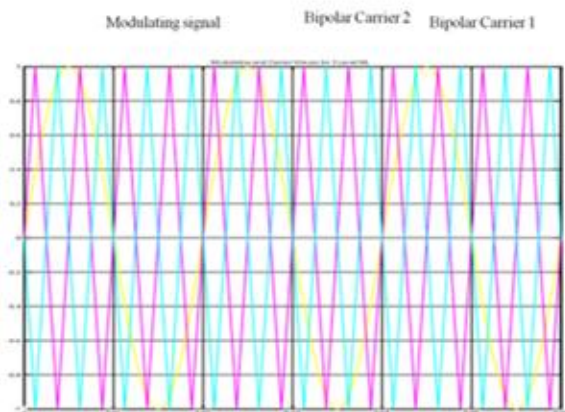

Fig 5: Bipolar switching sequence generation

In this paper Bipolar and Unipolar switching schemes with sinusoidal and third harmonic based sinusoidal switching schemes are used for generation of switching sequences for inverter switching. In bipolar switching scheme carrier signal have both positive and negative polarities whereas in unipolar switching scheme carrier signal have only one polarity that is either in positive or in negative. Different carrier and modulating signals are shown in fig 3 to 10.

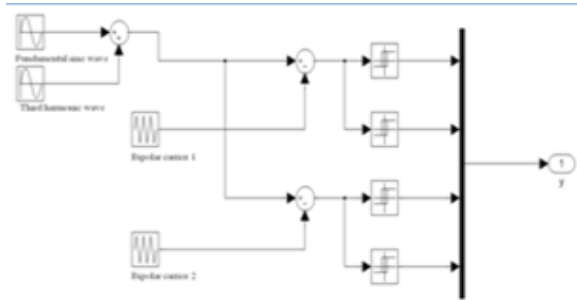

Fig 7: Unipolar switching sequence With 3rd Harmonic modulating signal.

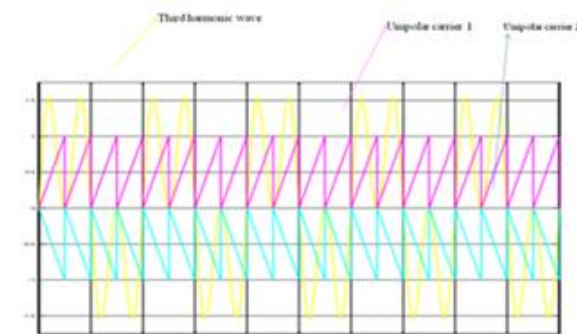

Fig 8: Unipolar 3rd Harmonic Signals.

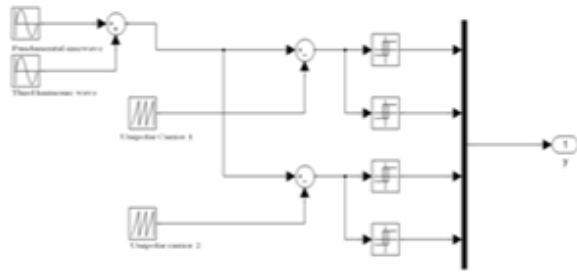

Fig 9: Bipolar switching sequence With 3rd Harmonic modulating signal.

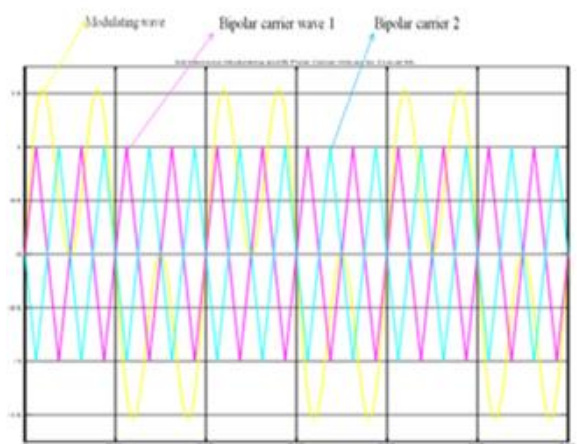

Fig 10: Bipolar 3rd Harmonic Signals

IV. Model Simulation & Results

Different control schemes proposed in chapter III are applied to a 3-Level, 5-Level, 7-Level, 9-Level

and 11-inverters for identification of switching scheme that gives minimum harmonic distortion. MATLAB simulations are done for different indexes. Observations made on the different converter circuits are presented in table – I and Table – II for modulation index vales 0.9 and 1.0 respectively.

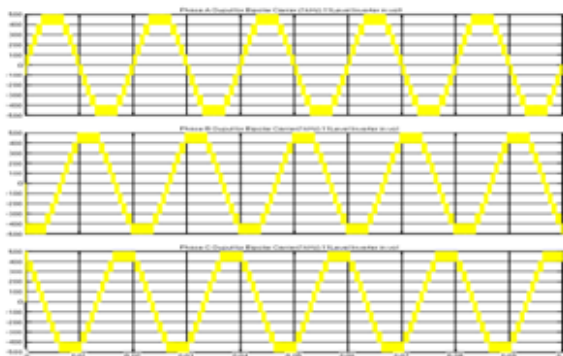

Fig 11: Voltage of 11 level 3 Phase CHB across load terminals with Bipolar SPWM switching When mIndex = 1

Name of Control Technique	Level of Inverter output voltage	% of Output Voltage	% THD
Unipolar Carrier Based SPWM	3	90.11	63.33
	5	90.11	63.33
	7	90.11	63.33
	9	90.11	63.33
	11	90.11	63.33
Bipolar Carrier Based SPWM	3	90.07	64.11
	5	90.04	33.32
	7	90.05	22.41
	9	90.06	16.68
	11	89.99	13.21
Unipolar Carried Based Third Harmonic SPWM	3	103.6	54.78
	5	103.6	54.78
	7	103.6	54.78
	9	103.6	54.78
	11	103.6	54.78
Bipolar Carrier Based Third Harmonic SPWM	3	103.6	56.71
	5	103.5	37.76
	7	103.5	31.13
	9	103.5	27.9
	11	103.6	25.96

Table I: Observation table for mIndex = 0.9

Name of Control Technique	Level of Inverter output voltage	% of Output Voltage	% THD
Unipolar Carrier Based SPWM	3	100.1	51.11
	5	100.1	51.11
	7	100.1	51.11
	9	100.1	51.11
	11	100.1	51.11
Bipolar Carrier Based SPWM	3	99.99	52.1
	5	99.98	26.94
	7	100	18.08
	9	99.98	13.75
	11	99.98	11.08
Unipolar Carried Based Third Harmonic SPWM	3	114.5	41.73
	5	114.5	41.73
	7	114.5	41.73
	9	114.5	41.73
	11	114.5	41.73
Bipolar Carrier Based Third Harmonic SPWM	3	114.7	43.9
	5	114.7	31.21
	7	114.8	27.62
	9	114.7	26.1
	11	114.8	25.19

Table – II: Observation table for mIndex = 1

V. Conclusion

It is observed that irrespective of the level of the circuit Bipolar Sinusoidal Pulse Width Modulation Scheme gives rise to least magnitude of Total Harmonic Distortion when compared with the other proposed switching schemes. Unipolar switching scheme with Fundamental and third harmonic based modulating signals give more total harmonic distortion. Whereas bipolar swathing scheme with third harmonic modulating signal gives 14% higher output voltage compared to the output voltage magnitude of other switching schemes but total harmonic distortion is more compared to Bipolar Sinusoidal Pulse Width Modulation Scheme.

REFERENCES

- [1]. Zhiguo Pan, Fang Zheng Peng, Keith A. Corzine, Victor R. Stefanovic, John M. (Mickey) Leuthen, and Slobodan Gataric, "Voltage Balancing Control Of Diode-Clamped Multilevel Rectifier/Inverter Systems" IEEE Trans on Industry Applications, Vol. 41, No. 6, pp. 1698-1706, Nov/Dec 2005.
- [2]. Robert Stala, "The Switch-Mode Flying-Capacitor DC–DC Converters with Improved Natural Balancing", IEEE Trans. On Industrial Electronics, Vol. 57, No. 4, pp. 1369-1382, April 2010.
- [3]. M. Trabelsi, and L. Ben-Brahim, "Development Of A Grid Connected

- Photovoltaic Power Conditioning System Based On Flying Capacitors Inverter”, 8th International Multi-Conference on Systems, Signals & Devices, pp. 1-6, May 2011.
- [4]. Pablo Lezana, José Rodriguez, and Diego A. Oyaizu, “Cascaded Multilevel Inverter with Regeneration Capability and Reduced Number of Switches”, *IEEE Trans. On Industrial Electronics*, Vol. 55, No. 3, pp. 1059-1066, March 2008.
- [5]. G.P. Adam, O. Anaya-Lara, G.M. Burt, D. Telford, B.W. Williams, and J.R. McDonald, “Modular multilevel inverter: pulse width modulation and capacitor balancing technique”, Published in *IET Power Electronics*, Vol. 3, Iss. 5, pp. 702-715, 2010.
- [6]. Moncef Ben Smida and Faouzi Ben Ammar, “Modeling and DBC-PSC-PWM Control of a Three-Phase Flying-Capacitor Stacked Multilevel Voltage Source Inverter”, *IEEE Trans. On Industrial Electronics*, Vol. 57, No. 7, pp. 2231-2239, July 2010.
- [7]. Mohan M. Renge and Hiralal M. Suryawanshi, “Three-Dimensional Space-Vector Modulation to Reduce Common-Mode Voltage for Multilevel Inverter”, *IEEE Trans. On Industrial Electronics*, Vol. 57, No. 7, pp. 2324-2331, July 2010.
- [8]. Ahmed M. Massoud, Shehab Ahmed, Prasad N. Enjeti, and Barry W. Williams, “Evaluation of a Multilevel Cascaded-Type Dynamic Voltage Restorer Employing Discontinuous Space Vector Modulation”, *IEEE Trans. on Industrial Electronics*, Vol. 57, No7, pp.2398- 2410 July 2010.
- [9]. Karthikeyan, R.,Dr.chenthur, pandian,s.,”An algorithm for minimizing THD in multi level inverters with space vector modulation”,*IEEE Trans. on Industrial Electronics*, Vol.3, NO.5, pp3915-3921, 2011.